

PARTS LIST MODEL : FCH-20, -20-1F & FCH-20F, -20F-1F

EXPLODED VIEW

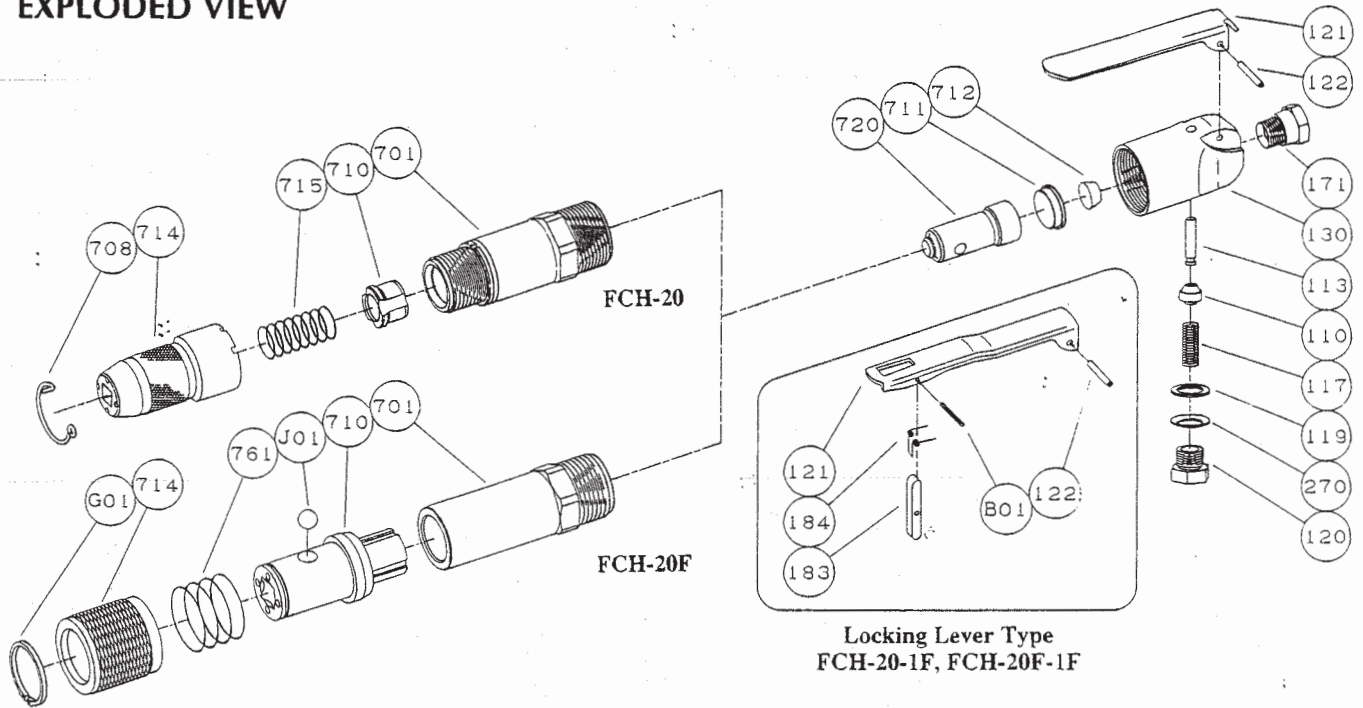

PARTS LIST

Index No.	Parts No.	Parts Name	Qt.
FCH-20, -20F			
Ass'y No.	H-001005-00	Cap Ass'y	
117	H-001117-00	Throttle Valve Spring	
119	H-001119-00	T.V. Cover Packing	
120	H-001120-00	Throttle Valve Cover	
121	H-063121-00	Throttle Valve Lever	
122	H-001122-00	Throttle Valve Lever Pin	
130	H-001130-00	Cap	
270	H-001270-00	Conical Spring Washer	
Ass'y No.	G-105008-00	Throttle Valve Rod Ass'y	
110	H-001110-02	Throttle Valve	
113	G-105113-00	Throttle Valve Rod	
FCH-20-1F, -20F-1F			
Ass'y No.	H-001005-01	Cap Ass'y	
117	H-001117-00	Throttle Valve Spring	
119	H-001119-00	T.V. Cover Packing	
120	H-001120-00	Throttle Valve Cover	
122	H-001122-00	Throttle Valve Lever Pin	
130	H-001130-00	Cap	
270	H-001270-00	Conical Spring Washer	
Ass'y No.	G-105008-00	Throttle Valve Rod Ass'y	
110	H-001110-02	Throttle Valve	
113	G-105113-00	Throttle Valve Rod	
Ass'y No.	H-001019-00	Locking Lever Ass'y	
121	A-192121-00	Throttle Valve Lever	
183	H-001183-00	Lock Key	

Index No.	Parts No.	Parts Name	Qt.
184	G-144184-00	Lock Spring	
B01	SP-218	Spring Pin	
FCH-20, -20-1F			
Ass'y No.	H-001007-00	Cylinder Ass'y	
701	H-001701-00	Cylinder	
710	H-001710-00	Chisel Bushing	
171	IB-202N00	Inlet Bushing <NPT>	
708	H-001708-00	Locking Clutch	
711	H-001711-00	Cylinder Cover	
712	H-001712-00	Damper	
714	H-001714-00	Chisel Holder	
715	H-001715-00	Holder Spring	
720	H-001720-00	Piston	
FCH-20F, -20F-1F			
Ass'y No.	H-002007-00	Cylinder Ass'y	
701	H-002701-A	Cylinder	
710	H-002710-A	Chisel Bushing	
171	IB-202N01	Inlet Bushing <NPT>	
711	H-001711-00	Cylinder Cover	
712	H-001712-00	Damper	
714	H-056714-00	Chisel Holder	
720	H-001720-00	Piston	
761	H-014761-00	Retainer Spring	
G01	SR-S28	Snap Ring	
J01	B-3/8	Ball	

- Ass'y No. denotes the assembled parts comprising of more than 1 pc. of parts. The related parts are shown in the thick frame.
- #171 is unnecessary in PT type.
- Specify parts number and quantity in ordering.

- Standard Accessory · FCH-20, -20-1F : G-2-1.....Flat Chisel 1.
· FCH-20F, -20F-1F : F-3-2.....Flax Chisel 1.
- Optional Accessory · FCH-20, -20-1F : HN-202000.....Hose Nipple 1.
· FCH-20F, -20F-1F : HN-202500.....Hose Nipple 1.

CHISELS

Blank Chisel
AC No. G-1
Series

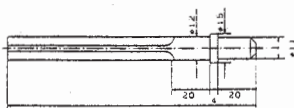

Flat Chisel
AC No. G-2
Series

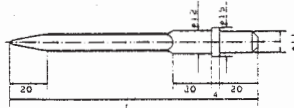

CHISELS LIST (FCH-20, -20-1F)

AC No.		Length (L) mm
Blank	Flat	
G-1-1	—	125
—	G-2-1	130
G-1-2	G-2-2	155
G-1-3	G-2-3	200
G-1-4	G-2-4	250

WITH TIP (Tungsten Carbide)

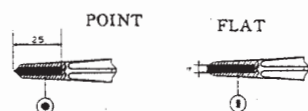

CHISELS LIST (FCH-20, -20-1F)

AC No.	Type	Length (L) mm	Remark
S-1	POINT	120	Standard
S-2	FLAT	120	Standard
S-3	POINT	160	Small Point
S-4-1	FLAT	160	Small Point

CHISELS LIST (FCH-20F, -20F-1F)

AC No.		Length (L) mm
Blank	Flat	
F-1-1	—	140
F-1-2	F-2-2 F-3-2	155
F-1-3	F-2-3 F-3-3	200
F-1-4	F-2-4 F-3-4	250
F-1-5	F-2-5 F-3-5	300

Blank Chisel
AC No. F-1
Series

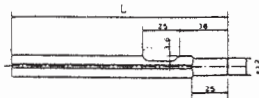

Flat Chisel
AC No. F-2
Series

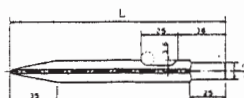

Flax Chisel
AC No. F-3
Series

